

MotorGuide® REPAIR PARTS

Model:
ST300V

SPECIFICATIONS:

Year	1996
Thrust	37LBS
Volts	12VDC
Amp Draw	0 to 48 amps
Mount	03
Speeds	Variable

PARTS ORDERING & TECH ASSISTANCE

MotorGuide Consumer Relations
Phone 918-831-6989
Fax 800-982-8093

Send Returned Goods to:

MotorGuide
605 Hwy 12 West
Starkville, MS 39760

Returned Goods must be accompanied with a Returned Goods Authorization. Contact MotorGuide Consumer Relations to obtain RGA.

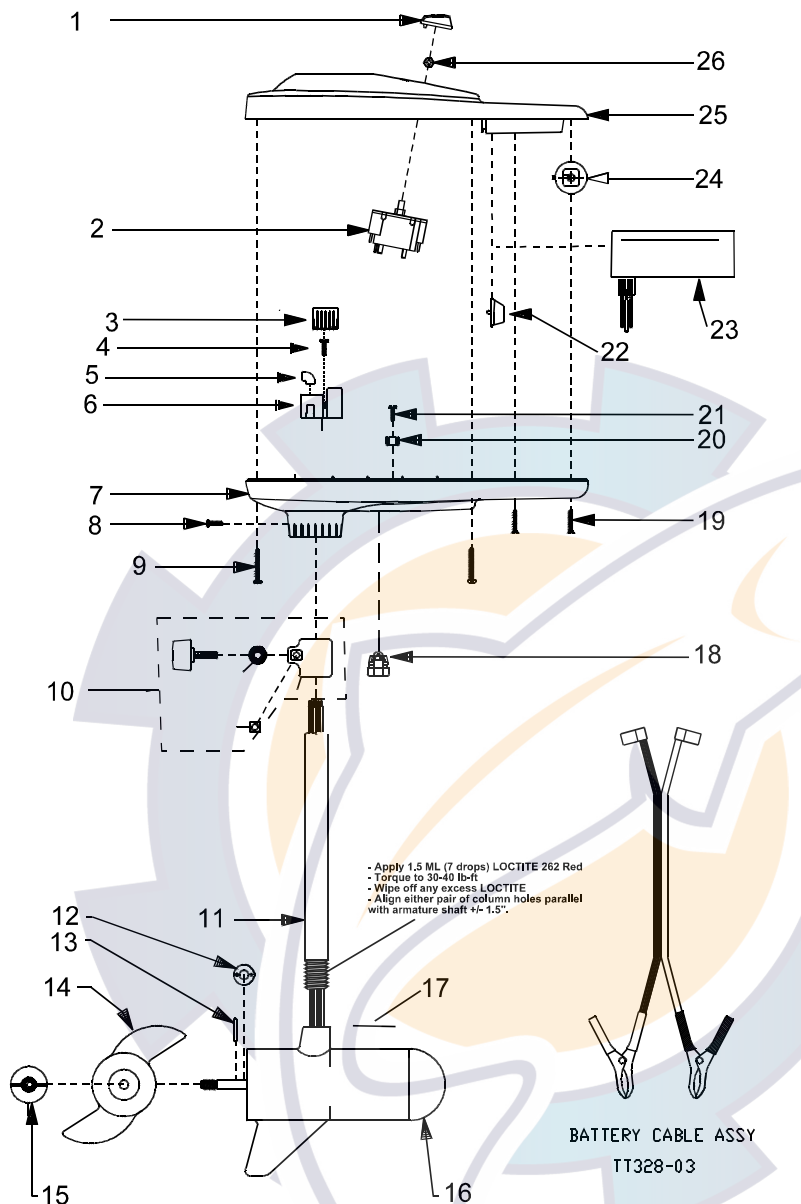

KEY	DESCRIPTION	PART #
1	KNOB	TT082-03
2	ROTARY SWITCH	KT150-02
3	AMP CONNECTOR	AP029-01
4	SCREW	AF141-01
5	INSULATOR	AT080-01
6	DA BOARD	JF157-03
7	T/H BASE	TF004-04
8	8 X 1-3/8 SCREW	AR133-01
9	8 X 1-3/8 SCREW	AR133-01
10	DEPTH COLLAR ASY	AR158-01
11	30" COLUMN	TT049-01
12	MONOFILAMENT WASHER	AR175-01
13	PROP DRIVE PIN	BR102-01
14	PROP	AF124-10
15	PROP NUT	AR099-01
16	MOTOR	KF397-03
17	MARINE LOWER UNIT DECAL	ET060-04
18	GROMMET	GR019-03
19	#4x 1" SCREW	TT141-02
20	TERMINAL	FT160-03
21	#10x 1/2" SCREW	GR133-01
22	POT ACTUATOR	TT3001-02
23	SLIDE POTENTIOMETER	TT168-03
24	ON/OFF HANDLE ASSY	TT372-01
25	T/H COVER	KT053-11
26	NUT	AT098-01

LOWER UNIT BREAKDOWN

Model:
ST300V

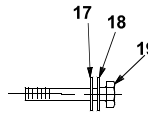
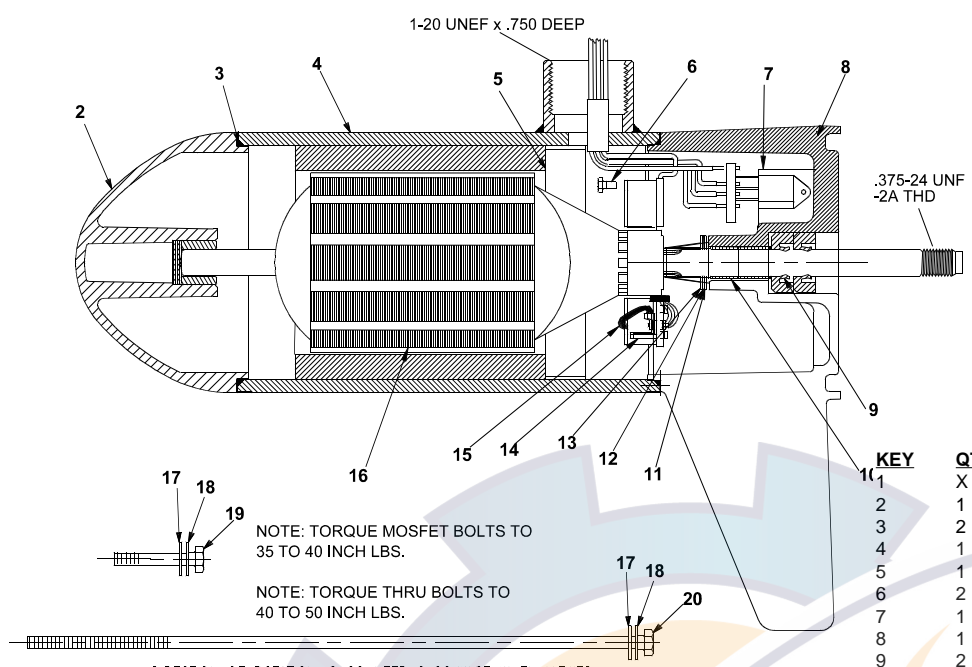

NOTE: TORQUE MOSFET BOLTS TO 35 TO 40 INCH LBS.
NOTE: TORQUE THRU BOLTS TO 40 TO 50 INCH LBS.

DIRECTION OF ROTATION IS COUNTER CLOCKWISE WHEN VIEWED FROM PROPELLER END WITH RED POSITIVE & BLACK NEGATIVE.

KEY	QTY	DESCRIPTION	PART NO.
1	X	MOTOR	KF397-03
2	1	NOSE CAP	JF3212-01
3	2	O RING SEAL	MR217-01
4	1	HOUSING ASY	KF3210-01
5	1	RETAINER	JF233-01
6	2	BRUSH CARD SCREW	MR228-01
7	1	DURA AMP MODULE	JF096-07
8	1	COMM CAP	JF3205-04
9	2	SHAFT SEAL	MR223-01
10	1	BEARING	MR206-01
11	1	NYLATRON WASHER	MR226-01
12	1	WASHER	MR227-01
13	1	E RING	MR219-02
14	2	BRUSH SPRINGS	MR214-02
15	1	BRUSH ASY LESS SPRING	JF3201-01
16	1	ARMATURE 3.5"	KF3207-01
17	4	STATIC SEAL	MR222-01
18	4	THRU BOLT WASHER	MR216-01
19	2	DURA AMP SCREW	MR229-04
20	2	THRU BOLT	MR218-01

WIRING

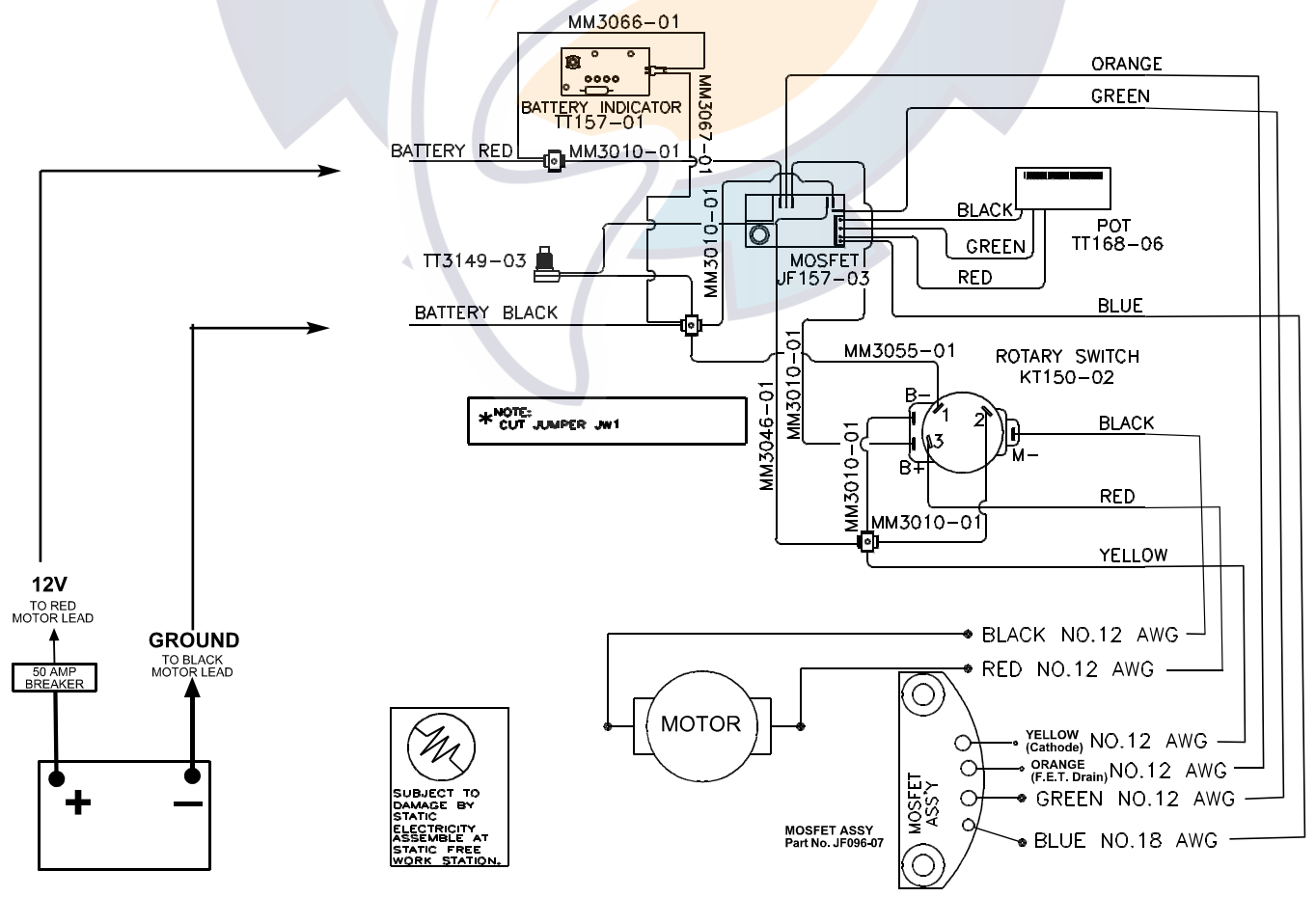

SUBJECT TO DAMAGE BY STATIC ELECTRICITY ASSEMBLE AT STATIC FREE WORK STATION.

MOSFET ASSY Part No. JF096-07